

Chapter 3 - Foundation

Things to Consider

- During this phase, Contractors & Volunteers will need to coordinate activities.
- Caution: Tie the sump pump switch up off of the floor to keep it from getting wet.

Components

Footers	Foundation Walls	Post pad
Sump Pump	Interior Drainage	Backfill
Temporary Power Pole	Sewer Tap	Water Tap
Gas Tap		

Timing & Prerequisites

- This is the initial phase of the build.
- The Habitat Supervisor will work with the contractors to initiate this phase and co-ordinate the timing of Contractor and Volunteer activities throughout the phase.

Figure 3.1 – Foundation

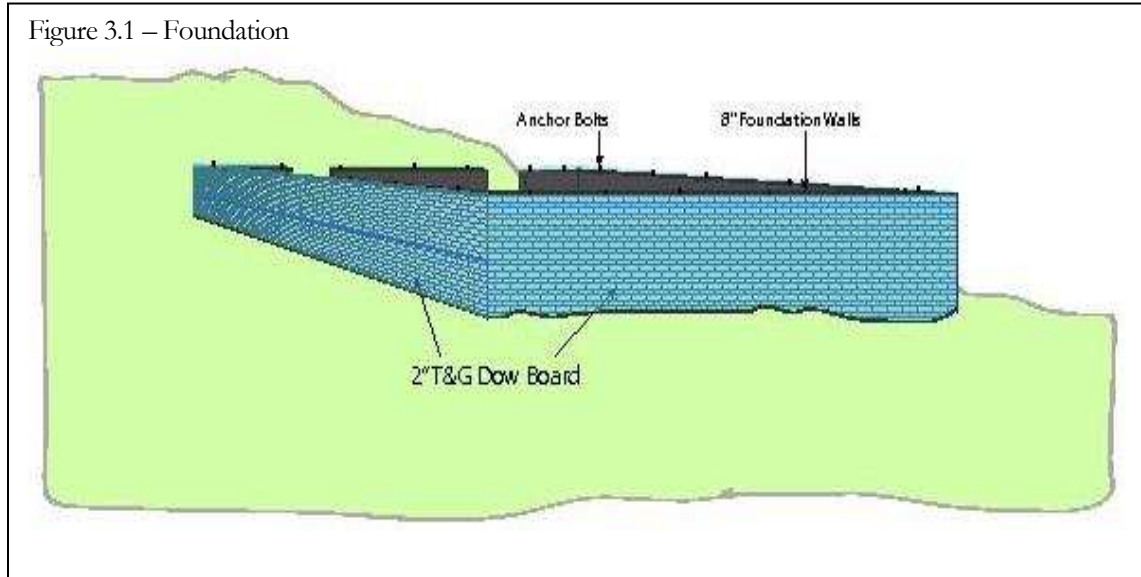

Materials Needed

Basement Floor Insulation	Basement Wall Insulation
2" T&G Dow Board 1/2" Dow Board Tyvek Tape Silicone Sealant	1 1/2" Thermax® 2" Dow Styrofoam Construction Adhesive Tyvek Tape Dow Clip Strips Dow J-channel Dow White Foil Tape 3 1/2" tap cons
Interior Drainage	Radon System
3" Perforated PVC Pipe Gravel Sump Pit	4" Solid PVC Pipe

Phase Specific Tools Needed

- Impact Drill
- Concrete Saw

Activities (New Build & Additions)

Foundation (Contractor)

The cement contractor will:

- Excavate the hole for the house
- Pour the footers
- Frame up the basement walls
- Pour the walls
- Clean off the frames
- Install the bituminous asphalt coating
- Install the exterior drainage
- Install the 2" tongue and groove (T&G) Dow board on the exterior foundation walls

Note: the Dow board will install vertically with pieces of 2" Dow used to space it off of the footer. This will bring the Dow board 2" above the foundation walls.

Utility Taps (Contractor)

The plumber will install the water tap, sewer tap, and gas tap.

Interior Drainage (Contractor)

1. The plumber will install the sump pump & interior drainage.
2. The cement contractor will install 4" of gravel over the interior drainage.

Basement Slab Insulation (Volunteers)

1. The Habitat Volunteers will install Dow Board for the thermal break under the basement slab. (See Figures 3.2a & 3.2b).
 - Cut 6" wide strips of 1/2" Dow board.
 - Install 1/2" strips along the outer edges of the foundation walls. The strips will rest on the gravel.
 - Cut and install 2" T&G Dow board over the gravel. The 2" Dow will fit snugly to the 1/2" Dow on the exterior walls and will fill all of the voids.
 - Tape the seams in the Dow board with Tyvek tape.

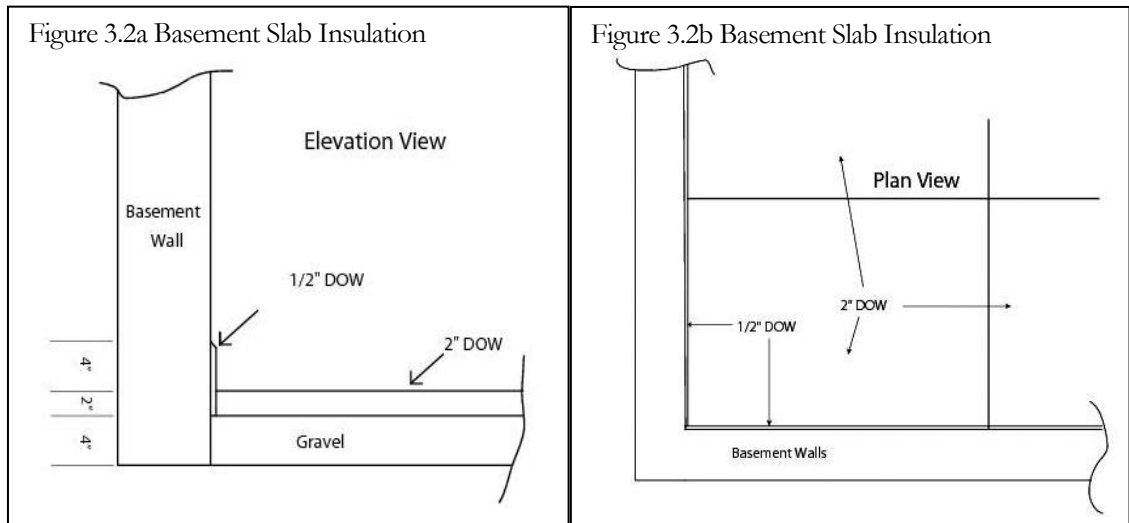

Temporary Sill Cover (Volunteers)

1. Cut 7" wide strips of 2" Dow boards. (See Figure 3.3)
2. Lay strips on top of the foundation wall; flush with the foundation Dow. Push it down over the bolts.
3. Tape the foundation Dow board to the Dow strips with Tyvek tape.

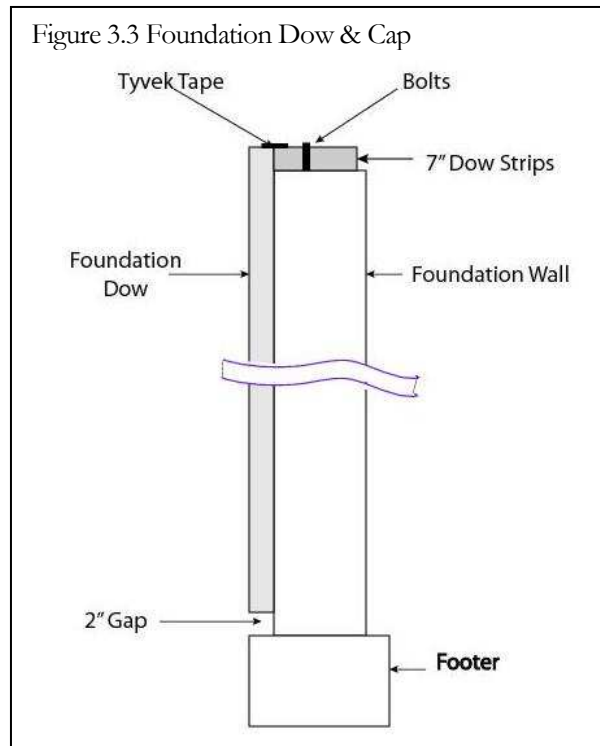

Basement Slab (Contractor)

1. The cement contractor will install 6 mil polyethylene plastic over the Dow board to create a vapor barrier.
2. The cement contractor will pour the basement floor.

Pour the A/C Pad

1. The cement contractor will pour the pad of the a/c condenser.

Backfill the foundation (Contractor)

1. Once the slab is poured and the utilities taps are installed, the contractor will backfill the foundation.

Caulk Basement Slab (Volunteers)

1. After the first floor deck is installed, apply a large bead of silicone caulk to the outside perimeter of the basement slab and around the sump pump pit. Any cracks or penetrations in the basement slab must be caulked.

Temporary Power Pole (Contractor)

1. The electrical contractor will install the temporary power pole and grounding rod.
2. AEP will connect up the power.

Activities (ReBuild)

The following tasks may be performed at the discretion of the Construction Supervisor depending on the condition of the existing foundation. A combination of contractors and volunteers will be used as appropriate for the level of expertise needed for the task.

Foundation Wall Repair (Contractor)

If the foundation walls are bowed, the contractor will install reinforcing steel beams to the walls.

Foundation Wall Repair (Volunteer)

If the foundation walls have cracks or holes in the mortar, the cracks and holes will be filled with silicone caulk.

Foundation Wall Insulation (Volunteers)

The foundation walls will be covered with 2" Dow board and 1 ½" Thermax®. The seams in the Thermax® should not line up with the seams in the Dow board.

Masks and gloves must be worn when cutting or handling Thermax®.

1. Cut 4x8 sheets of 2" Dow Styrofoam to fit the wall horizontally. Cut off 12" of the first sheets of each wall so the first vertical seam is 7' from the corner.
2. Attach the 2" Dow Styrofoam to the wall with construction adhesive. The construction adhesive will hold the sheets until the Dow J-channel is installed.
3. Tape the Dow Styrofoam joints with Tyvek tape.
4. Cut the 4x8 sheets of 1 ½" Thremax® to fit the walls with the 8' dimension installed vertically.
5. Starting in one corner of the basement, attach a Dow J-channel vertically to the wall using 3 ½" tap-cons 12" OC; through the holes in the nail fin; through the 2" Dow Styrofoam and into the cement wall. (See Figure 3.4). Bend the J-channel to fit over bowing walls.
6. Apply a bead of silicone sealant to the flange.
7. Insert the first sheet of Thermax®. A slight bending of the board may be required to get it into the channel. Do not over bend the board, it will crack. If the board cracks, apply Dow white foil tape over the crack.
8. Position a Dow Clip Strip on the opposite side of the board with the flange edge exposed. Attach the Clip Strip with tap-cons through the holes.

9. Apply a bead of sealant to the flange and insert the next Thermax® panel.
10. Tape the seams with Dow White Foil Tape.

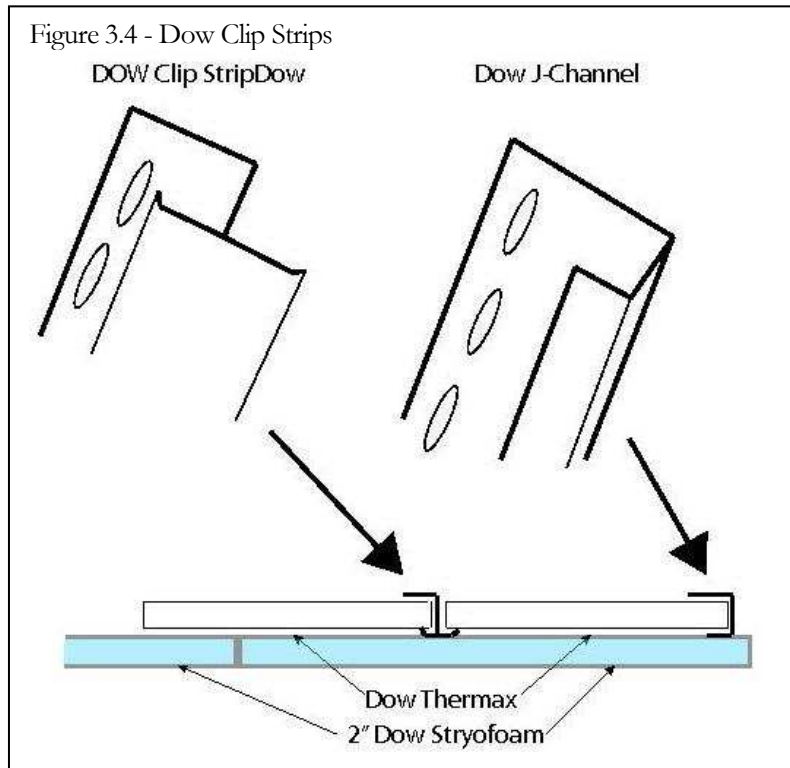

Interior Drainage & Sump Pump (Optional)

1. Cut the existing concrete floor 12" from each of the exterior walls.
2. Break out and remove the concrete between the line and the Wall. Remove the gravel and dirt below the floor to a depth of 8".
3. Cut and remove the concrete, gravel and dirt for the sump pump pit. The hole should be 18" x 18" wide and 2" deeper than the pit is tall.
4. Drill 3" holes in the sides of the sump pump pit to allow installation of the PVC pipe.
5. Cut perforated 3" PVC pipe along the wall in the trench.
6. Install 2 or 3" of gravel in the trench and the sump pump hole.
7. Install the sump pump pit with the lip just above the existing or planned basement floor level.
8. Install the PVC pipe in the trench. Start at the sump pump pit and keep the piping level entirely around the foundation. The perforated holes must face down. Add gravel as need to support the piping.

9. Infill the remaining space in the trench with gravel until it is even with the bottom of the basement slab.

Post Pads (Volunteers)

If new support posts are to be installed based on the architect's prints, new cement pads will be installed.

1. Cut a 12" by 12" hole in the existing floor.
2. Remove cement, gravel and dirt to a depth of 8"
3. Fill the hole with concrete. Trowel off the concrete even with the existing floor.

Basement Floor (Contractor)

If the basement floor has been cut or is significantly cracked and broken, the cement contractor will pour a new concrete slab. The existing slab may or may not be removed.

Radon (Volunteers)

Both new builds and ReBuild basements will be tested for Radon. If the levels of Radon gas are actionable, an active Radon system will be installed.